

- > Port size: DN 8 ... 25, 1/4" ... 1" (ISO G/NPT)
- > Compact build piston valve
- > Functional design
- > High flow rate
- > Piston guided in PTFE rings
- > Long lifetime
- > Solenoid interchangeable without tools (*Click-on*)
- > Leakrate E acc. to DIN EN 12266-1



Technical features

Medium:

Neutral steam and liquids

Switching function:

Normally closed

Operation:

Indirectly solenoid actuated

Mounting:

Optional, preferably solenoid vertical on top

Flow direction:

Determined

Port size:

G1/4, G3/8, G1/2, G3/4, G1, 1/4 NPT, 3/8 NPT, 1/2 NPT, 3/4 NPT, 1 NPT

Operating pressure:

1 ... 25 bar (14,5 ... 362 psi)

Fluid temperature:

0° ... +200°C (+32° ... +392°F)*3)

Ambient temperature:

0° ... +50°C (+32° ... +122°F) *3) with solenoid mounted vertical underneath max. +60 °C (+140°F)*4)

Material:

Body: Brass (CW617N)

Seat seal: PTFE

Internal parts: Stainless steel, FPM, PTFE

For contaminated fluids insertion of a strainer is recommended.

Technical data - standard models

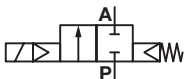
Symbol	Port size	Orifice (mm)	Flow kv value *1) (m³/h)	Operating pressure *2) (bar)	(psi)	Weight (kg)	Model Solenoid in V d.c./a.c.
	G1/4	8	2,2	1 ... 25	14,5 ... 362	0,83	8538000.9152.xxxxx
	1/4 NPT	8	2,2	1 ... 25	14,5 ... 362	0,83	8539000.9152.xxxxx
	G3/8	10	3,4	1 ... 25	14,5 ... 362	0,82	8538100.9152.xxxxx
	3/8 NPT	10	3,4	1 ... 25	14,5 ... 362	0,82	8539100.9152.xxxxx
	G1/2	12	4,4	1 ... 25	14,5 ... 362	0,85	8538200.9152.xxxxx
	1/2 NPT	12	4,4	1 ... 25	14,5 ... 362	0,85	8539200.9152.xxxxx
	G3/4	20	7	1 ... 25	14,5 ... 362	1,25	8538300.9152.xxxxx
	3/4 NPT	20	7	1 ... 25	14,5 ... 362	1,25	8539300.9152.xxxxx
	G1	25	10,5	1 ... 25	14,5 ... 362	1,7	8538400.9152.xxxxx
	1 NPT	25	10,5	1 ... 25	14,5 ... 362	1,7	8539400.9152.xxxxx

xxxxx Please insert voltage and frequency codes

*1) Cv-value (US) ≈ kv value x 1,2

*2) For gases and liquid fluids up to 40 mm²/s (cSt)

*3) Temperature <0 °C on request

*4) Temperature max. +55°C within the scope of cCSAus

Option selector

853*****.9152.*****

Thread form	Substitute
ISO G	8
NPT	9
Port size	Substitute
1/4"	0
3/8"	1
1/2"	2
3/4"	3
1"	4
Valve options	Substitute
Normally open (NO), Operating pressure 1 ... 16 bar	01
Manual override	02

Frequency	Substitute
See table frequency codes	xx
Voltage	Substitute
See Voltage codes	xxx

Standard solenoid systems

Voltage and Frequency Solenoid 9152 *1)					
Code Voltage	Code Frequency	Voltage	Frequency	Power consumption	
				Inrush	Holding
024	00	24 V d.c.	-	10 W	10 W
024	50	24 V a.c.	50 Hz	45 VA	10 W
110	50	110 V a.c.	50 Hz	45 VA	10 W
120	60	120 V a.c.	60 Hz	45 VA	10 W
230	50	230 V a.c.	50 Hz	45 VA	10 W

Electrical details for all solenoid systems

Design	DIN VDE 0580
Voltage range	±10%
Duty cycle	100% ED
Protection class	EN 60529 IP65
Socket	Form A acc. to DIN EN 175301-803 (included)

According to DIN VDE 0580 at a solenoid temperature of +20°C.
At operating state temperature the input power of a coil decreases by up to ca. 30% due to physical reasons.

*1)  _{US} coil only / up to +55°C ambient temperature

Further versions on request!

Section View

G1/4 ... 1
1/4 ... 1 NPT

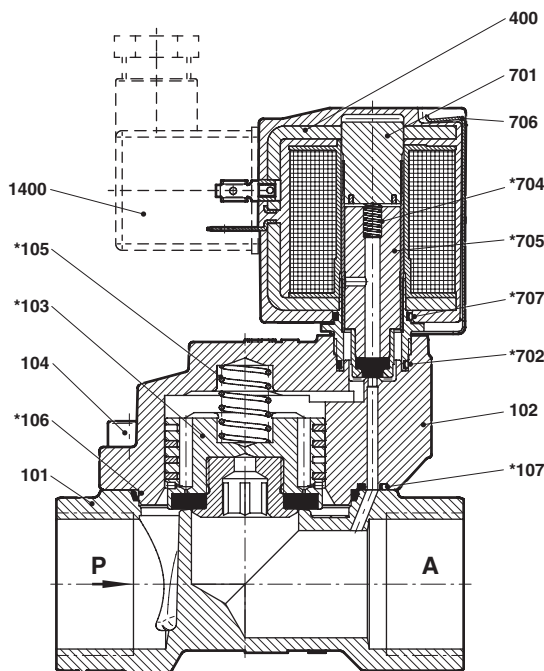

No.	Description
101	Valve body
102	Valve cover
*103	Valve plate
104	Allen head screw
*105	Pressure spring
*106	Gasket
*107	O-ring / gasket
400	Solenoid
701	Core tube
*702	O-ring
*704	Pressure spring
*705	Plunger
706	Spring clip
*707	O-ring
1400	Socket (included)

* These individual parts form a complete wearing unit.
When ordering spare parts please state Model No. and Series No.

Dimensions
G1/4 ... 1
1/4 ... 1 NPT

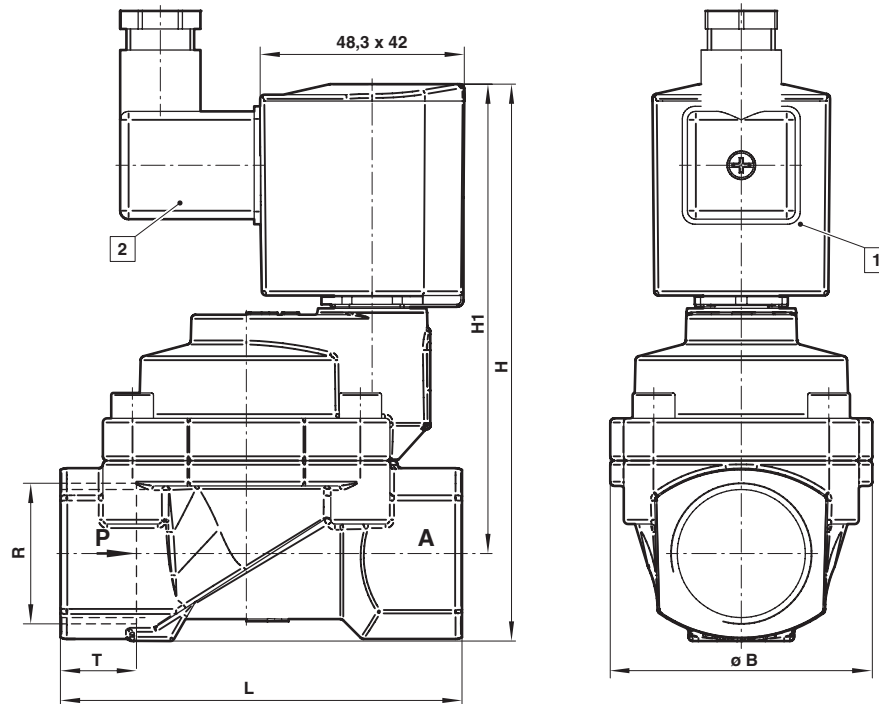
 Dimensions in mm
 Projection/First angle

- 1 Solenoid rotatable 360°
2 Socket turnable 4 x 90°
 (Socket included)

Port size R	ø B	H	H1	L	T	Model
G1/4	44	105	93,5	60	12	8538000.9152.xxxxx
1/4 NPT	44	105	93,5	60	12	8539000.9152.xxxxx
G3/8	44	105	93,5	60	12	8538100.9152.xxxxx
3/8 NPT	44	105	93,5	60	12	8539100.9152.xxxxx
G1/2	44	107,5	102,5	67	14	8538200.9152.xxxxx
1/2 NPT	44	107,5	102,5	67	14	8539200.9152.xxxxx
G3/4	50	119	102,5	80	16	8538300.9152.xxxxx
3/4 NPT	50	119	102,5	80	16	8539300.9152.xxxxx
G1	62	131,5	110,5	95	18	8538400.9152.xxxxx
1 NPT	62	131,5	110,5	95	18	8539400.9152.xxxxx

Note to Pressure Equipment Directive (PED):

The valves of this series, including the connection size DN 25 (G 1), are according to Art. 3 § 3 of the Pressure Equipment Directive (PED) 97/23/EG. This means interpretation and production are in accordance to engineers practice wellknown in the member countries. The CE-sign at the valve refers not to the PED. Thus the declaration of conformity is not longer applicable for this directive.

For valves > DN 25 (G 1) Art. 3 § (1) No.1.4 applies:

The basic requirements of the Enclosure I of the PED must be fulfilled. The CE-sign at the valve includes the PED. A certificate of conformity of this

directive will be available on request.

Note to Electromagnetic Compatibility Guideline (EEC):

The valves shall be provided with an electrical circuit which ensures the limits of the harmonised standards EN 61000-6-3 and EN 61000-6-1 are observed, and hence the requirements of the Electromagnetic Compatibility Guideline (2004/108/EG) satisfied.